



Cam Units CLC  
Schieber CLC  
Unità a Camme CLC

**OMCR**<sup>®</sup>  
STANDARD DIE COMPONENTS

OMCR CODE	Work Angle	Slider Width (mm)	Closed Cam Height (mm)	Work Area W x H (mm)	Max Work Force with shoulder 10 <sup>6</sup> cycles (kN)	Extraction Force (kN)	Page number
	$\beta$				F <sub>s</sub>	F <sub>t</sub>	
CLC050	0÷70°	50	200	50x75	41	0,35÷0,71	860
CLC065	0÷70°	65	180 (0÷45°) 190 (50÷55°) 210 (60÷70°)	65x65	42	0,44÷0,94	864
CLC080	0÷70°	80	270	80x86	83	0,58÷1,20	868
CLC150	0÷70°	150	270	150x85	140	1,66÷4,18	872



Highly skilled workers

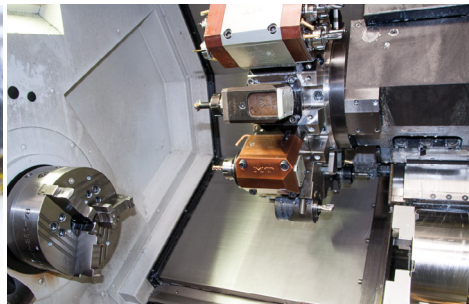

## AERIAL CAM UNIT - OBEN HÄNGENDER SCHIEBER - UNITÀ A CAMME SOSPESA

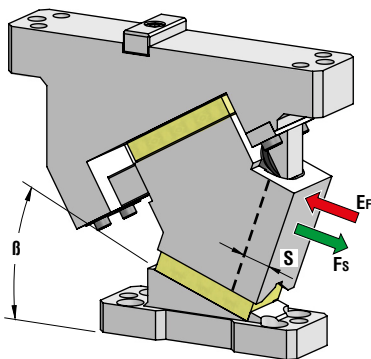

OMCR CODE	Work Angle	Stroke (mm)	Max Work Force with shoulder (kN)	Extraction Force (kN)
	$\beta$	S	$F_s$	$E_f$ Spring
CLC050.00	0°	30,21	41	0,66
CLC050.05	5°	30,52	41	0,61
CLC050.10	10°	30,34	41	0,56
CLC050.15	15°	30,53	41	0,71
CLC050.20	20°	30,41	41	0,66
CLC050.25	25°	30	41	0,66
CLC050.30	30°	32,55	41	0,66
CLC050.35	35°	35,38	41	0,66
CLC050.40	40°	38,57	41	0,66
CLC050.45	45°	42,26	41	0,66
CLC050.50	50°	46,67	41	0,66
CLC050.55	55°	52,10	41	0,59
CLC050.60	60°	59,09	41	0,52
CLC050.65	65°	58,26	41	0,38
CLC050.70	70°	57,59	41	0,35

### OPTION CODE

SL	1 ÷ 60 (1mm steps)
SW	65 mm
N	Ø 12H7

### OPTION CODE



Art.	Work Angle = 5°	SL	SW	N
CLC050	05	SL55	SW65	N12

OMCR CODE	Work Angle	Overall Dimensions (mm)			
	$\beta$	A	B	C	D
CLC050.00	0°	225	77,50	107	257
CLC050.05	5°	226,91	78,33	100	250
CLC050.10	10°	223,72	79,93	90	240
CLC050.15	15°	224,36	82,29	85	235
CLC050.20	20°	220,76	85,39	70	220
CLC050.25	25°	215,85	89,22	58	208
CLC050.30	30°	213,58	94,73	55	205
CLC050.35	35°	204,89	96,90	35	185
CLC050.40	40°	206,72	102,69	30	180
CLC050.45	45°	202,01	103,06	20	170
CLC050.50	50°	195,73	105,94	10	160
CLC050.55	55°	189,83	116,30	0	150
CLC050.60	60°	179,27	125,08	-15	135
CLC050.65	65°	176,60	126,87	-32	118
CLC050.70	70°	177	135,83	-38	112

AERIAL CAM UNIT - OBEN HÄNGENDER SCHIEBER - UNITÀ A CAMME SOSPESA

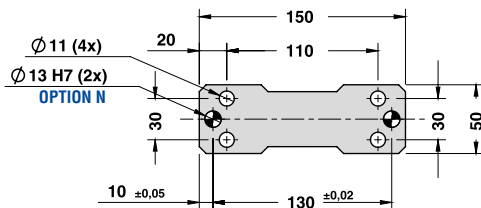
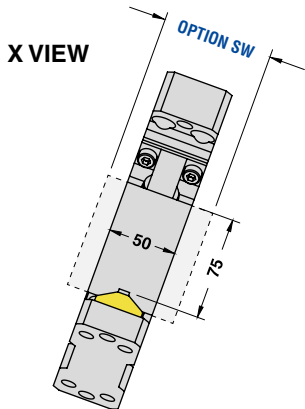

CAM DIAGRAM

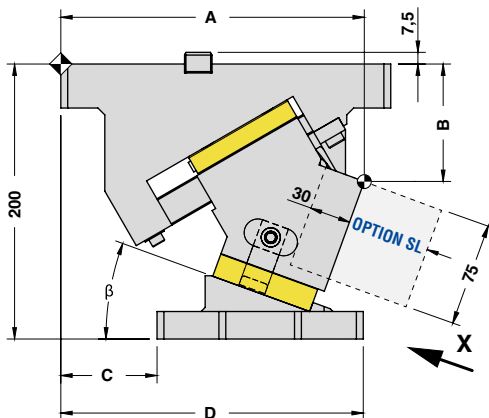
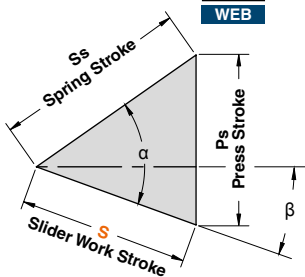

Work Angle	Inner Angle	Slider Work Stroke (mm)	Press Stroke (mm)	Spring Stroke (mm)
$\beta$	$\alpha$	S	Ps	Ss

0°	50°	30,21	36,00	47
5°	50°	30,52	33,07	43
10°	50°	30,34	30,34	39
15°	50°	30,53	28,55	36
20°	50°	30,41	26,90	33
25°	50°	30,00	25,36	30
30°	50°	32,55	26,54	30
35°	50°	35,38	28,06	30
40°	50°	38,57	30,00	30
45°	50°	42,26	32,50	30
50°	50°	46,67	35,75	30
55°	50°	52,10	40,07	30
60°	50°	59,09	45,96	30
65°	55°	58,26	48,46	25
70°	60°	57,59	50,64	20

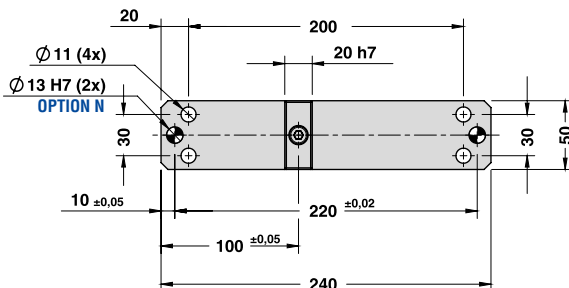

**AERIAL CAM UNIT - OBEN HÄNGENDER SCHIEBER - UNITÀ A CAMME SOSPESA**

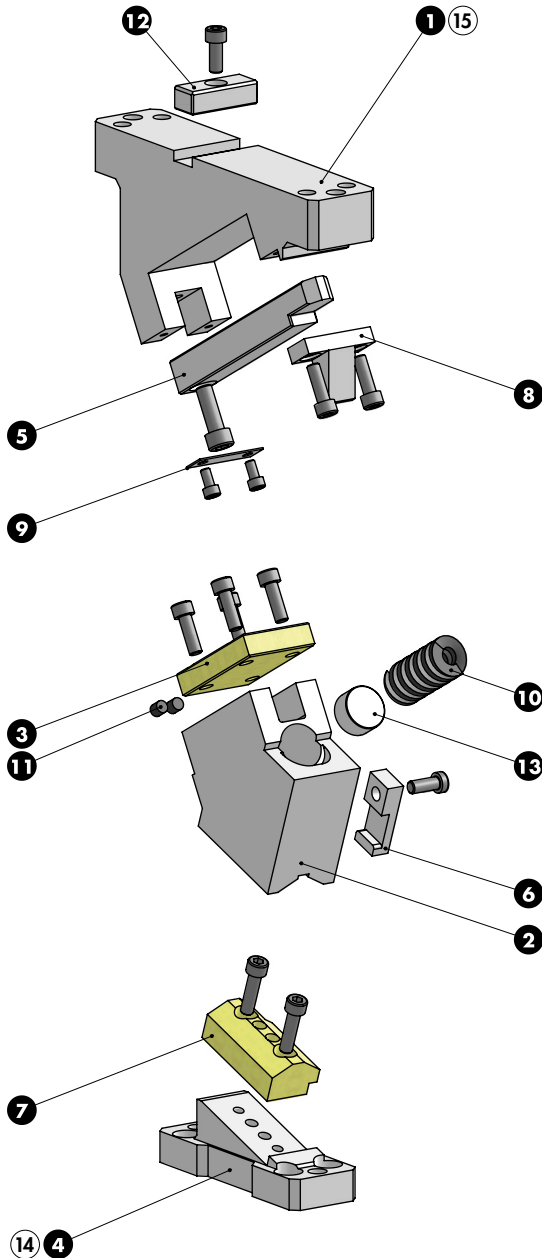

**AERIAL CAM UNIT - OBEN HÄNGENDER SCHIEBER - UNITÀ A CAMME SOSPESA**

**SLIDER STRUCTURE, POSITIVE RETURN STRUCTURE AND CLEARANCES**

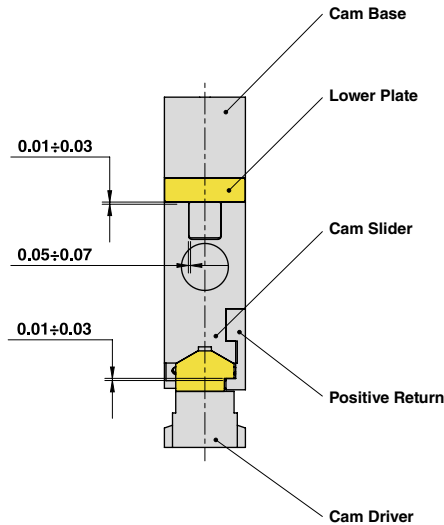

Cam Units CLC

**PART LIST**

Particular number	Description	Material	Quantity
1	Cam Base	GGG-50	1
2	Cam Slider	GGG-50	1
3	Plate	CuZn25Al5 + Graphite - HB > 190	1
4	Cam Driver	GG-25	1
5	Guide Bar	42CrMo4 + Graphite	1
6	Positive Return	CK45	1
7	Male "V" Driver	CuZn25Al5 + Graphite - HB > 190	1
8	Spring Block	St44	1
9	Safety Plate	St44	1
10	Spring	-	1
11	Elastomer Cap	Elastomer 92SH	2
12	Key	CK45	1
13	Spring Spacer	CK45	1
14	Cam Driver Fixing Screws M10x35 DIN 912	-	4
15	Cam Base Fixing Screws M10x40 DIN 912	-	4

## AERIAL CAM UNIT - OBEN HÄNGENDER SCHIEBER - UNITÀ A CAMME SOSPESA

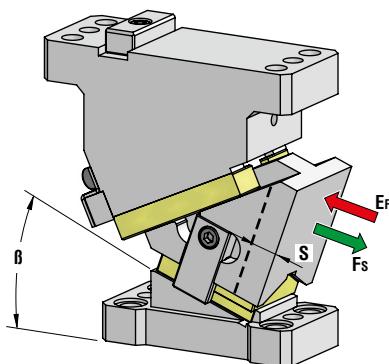

OMCR CODE	Work Angle	Stroke (mm)	Max Work Force with shoulder (kN)	Extraction Force (kN)
	$\beta$	S	$F_s$	$E_f$ Spring
CLC065.00	0°	14,99	42	0,94
CLC065.05	5°	15,07	42	0,89
CLC065.10	10°	15,22	42	0,91
CLC065.15	15°	15,51	42	0,87
CLC065.20	20°	16,49	42	0,87
CLC065.25	25°	17,10	42	0,79
CLC065.30	30°	18,51	42	0,85
CLC065.35	35°	19,57	42	0,77
CLC065.40	40°	21,46	42	0,85
CLC065.45	45°	23,25	42	0,77
CLC065.50	50°	26,50	42	0,79
CLC065.55	55°	29,70	42	0,70
CLC065.60	60°	34,97	42	0,64
CLC065.65	65°	41,37	42	0,54
CLC065.70	70°	51,12	42	0,44

### OPTION CODE

SL	1 ÷ 60 (1mm steps)
----	--------------------

### OPTION CODE



Art.	Work Angle = 5°	SL
CLC065	05	SL55

OMCR CODE	Work Angle	Overall Dimensions (mm)				
	$\beta$	A	B	C	D	E
CLC065.00	0°	170	53	60	190	180
CLC065.05	5°	171,41	60,27	55	185	180
CLC065.10	10°	177,16	63,06	55	185	180
CLC065.15	15°	177,20	66,33	50	180	180
CLC065.20	20°	176,51	70,01	40	170	180
CLC065.25	25°	172,94	75,64	35	165	180
CLC065.30	30°	177,78	78,32	30	160	180
CLC065.35	35°	173,29	83,25	20	150	180
CLC065.40	40°	170,78	82,44	10	140	180
CLC065.45	45°	165,50	86,51	2,5	132,5	180
CLC065.50	50°	165,41	96,79	-5	125	190
CLC065.55	55°	159,51	99,89	-10	120	190
CLC065.60	60°	156,68	120,78	-20	110	210
CLC065.65	65°	150,33	122,80	-25	105	210
CLC065.70	70°	146,45	131,68	-32	98	210

AERIAL CAM UNIT - OBEN HÄNGENDER SCHIEBER - UNITÀ A CAMME SOSPESA

X VIEW

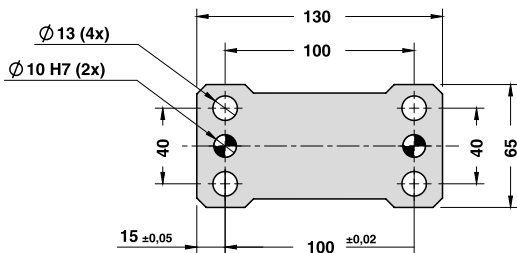
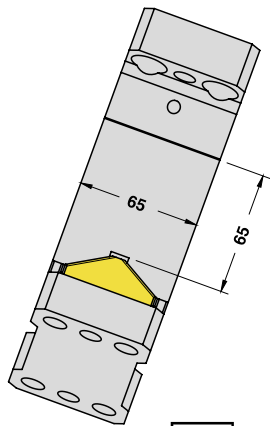

CAM DIAGRAM

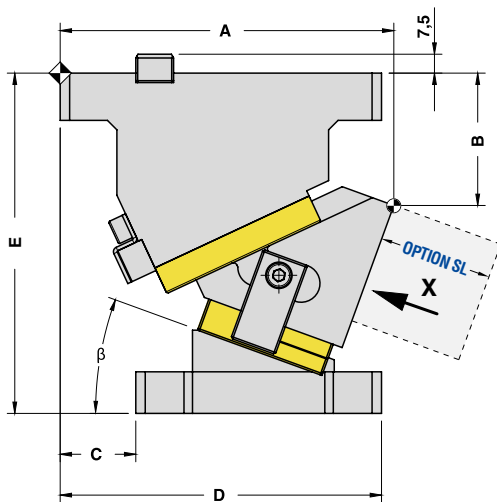
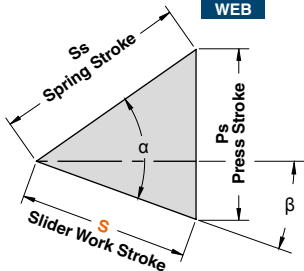

Work Angle	Inner Angle	Slider Work Stroke (mm)	Press Stroke (mm)	Spring Stroke (mm)
$\beta$	$\alpha$	S	Ps	Ss
0°	45°	14,99	14,99	21,2
5°	45°	15,07	13,91	19,6
10°	45°	15,22	13,14	18,3
15°	45°	15,51	12,66	17,3
20°	45°	16,49	12,87	17,1
25°	50°	17,10	14,45	17,1
30°	45°	18,51	13,55	16,6
35°	50°	19,57	15,52	16,6
40°	45°	21,46	15,23	16,5
45°	50°	23,25	17,88	16,5
50°	45°	26,50	18,81	17,1
55°	50°	29,70	22,84	17,1
60°	45°	34,97	25,60	18,1
65°	50°	41,37	32,81	18,1
70°	55°	51,12	43,35	18,1

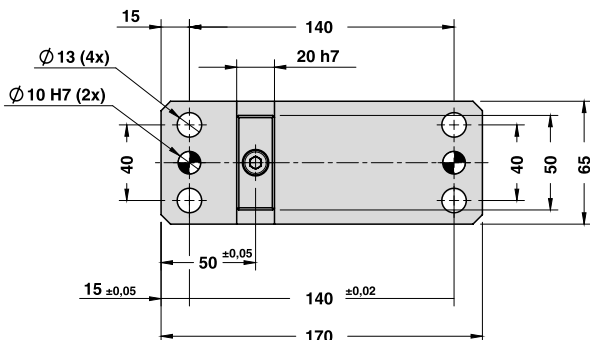

Cam Units CLC



**AERIAL CAM UNIT - OBEN HÄNGENDER SCHIEBER - UNITÀ A CAMME SOSPESA**

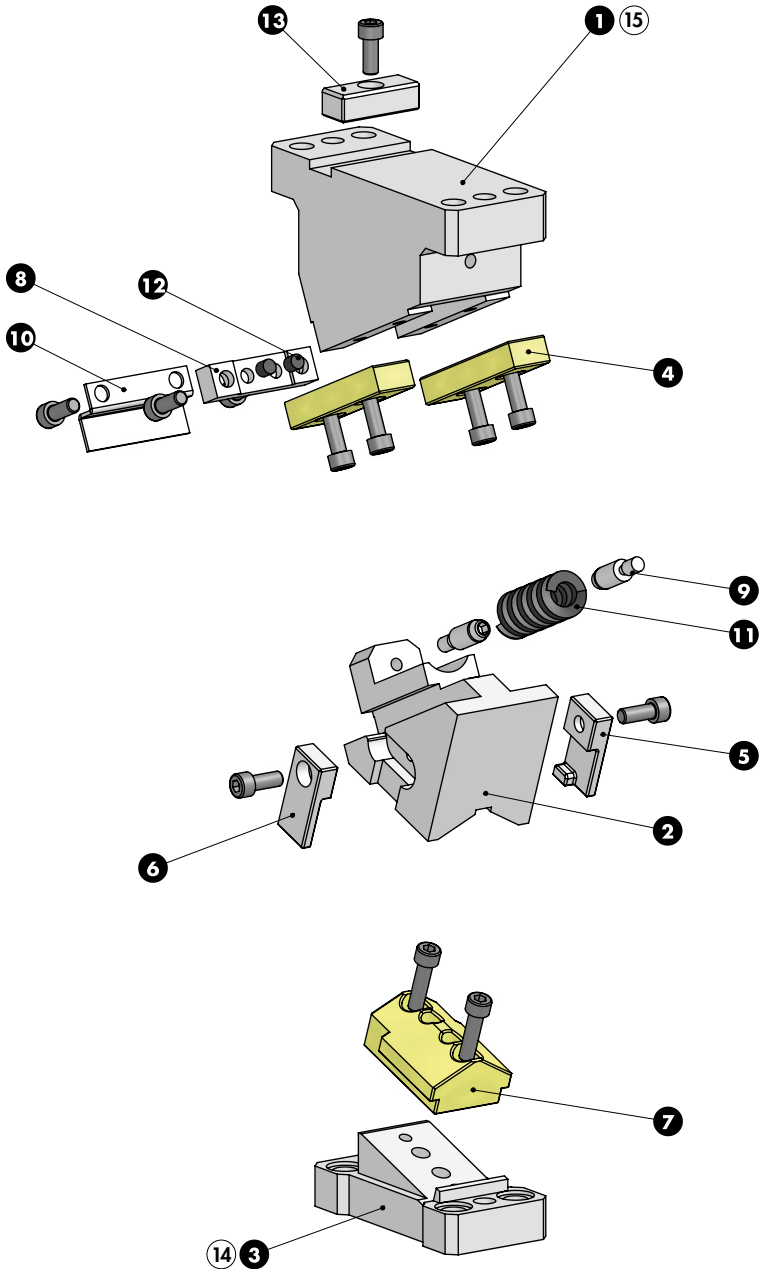

AERIAL CAM UNIT - OBEN HÄNGENDER SCHIEBER - UNITÀ A CAMME SOSPESA

SLIDER STRUCTURE, POSITIVE RETURN STRUCTURE AND CLEARANCES

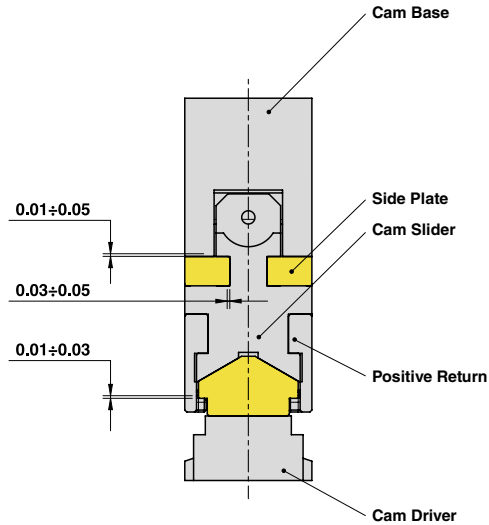

Cam Units CLC

PART LIST

Particular number	Description	Material	Quantity
1	Cam Base	GGG-45	1
2	Cam Slider	GG-25	1
3	Cam Driver	GG-25	1
4	Side Plate	CuZn25Al5 + Graphite - HB > 190	2
5	Positive Return R	CK45	1
6	Positive Return L	CK45	1
7	Male "V" Driver	CuZn25Al5 + Graphite - HB > 190	1
8	Stopper Plate	St44	1
9	Spring Guide Pin	34CrMo4	2
10	Safety Plate	St44	1
11	Spring	-	1
12	Elastomer Cap	Elastomer 92SH	2
13	Key	CK45	1
14	Cam Driver Fixing Screws M12x35 DIN 912	-	4
15	Cam Base Fixing Screws M12x35 DIN 912	-	4

## AERIAL CAM UNIT - OBEN HÄNGENDER SCHIEBER - UNITÀ A CAMME SOSPESA

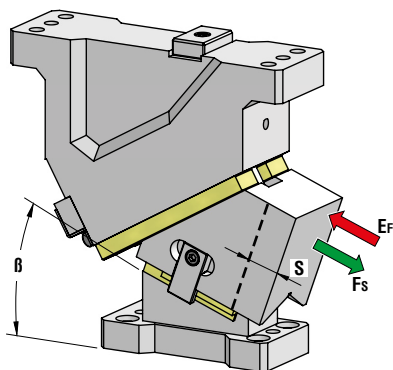

OMCR CODE	Work Angle	Max Stroke (mm)	Max Work Force with shoulder (kN)	Extraction Force (kN)
	$\beta$	S	Fs	Ef Spring
CLC080.00	0°	32,14	83	1,09
CLC080.05	5°	38,45	83	1,20
CLC080.10	10°	38,89	83	1,09
CLC080.15	15°	39,65	83	0,97
CLC080.20	20°	46,08	83	1,09
CLC080.25	25°	47,78	83	0,97
CLC080.30	30°	54,25	83	1,09
CLC080.35	35°	57,36	83	0,97
CLC080.40	40°	64,28	83	1,09
CLC080.45	45°	69,64	83	0,97
CLC080.50	50°	77,79	83	1,09
CLC080.55	55°	87,17	83	0,97
CLC080.60	60°	98,48	83	0,85
CLC080.65	65°	81,56	83	0,65
CLC080.70	70°	86,38	83	0,58

### OPTION CODE

SL	1 ÷ 60 (1mm steps)
SW	100 or 120 mm
N	Ø 16 H7

### OPTION CODE



Art.	Work Angle = 5°	SL	SW	N
CLC080	05	SL55	SW120	N16

OMCR CODE	Work Angle	Overall Dimensions (mm)				
	$\beta$	A	B	C	D	E
CLC080.00	0°	260	99	100	265	130
CLC080.05	5°	272,93	109,39	100	265	150
CLC080.10	10°	279,92	120,43	100	265	150
CLC080.15	15°	285,93	132,04	100	265	150
CLC080.20	20°	285,90	129,12	90	255	170
CLC080.25	25°	289,80	141,60	90	255	170
CLC080.30	30°	282,59	134,36	75	240	170
CLC080.35	35°	284,27	147,32	75	240	170
CLC080.40	40°	274,80	140,38	60	225	170
CLC080.45	45°	274,20	153,44	60	225	170
CLC080.50	50°	262,46	151,39	35	200	170
CLC080.55	55°	259,60	164,14	35	200	170
CLC080.60	60°	240,64	176,59	0	165	170
CLC080.65	65°	235,61	188,65	-5	160	170
CLC080.70	70°	227,83	195,53	-10	155	170



AERIAL CAM UNIT - OBEN HÄNGENDER SCHIEBER - UNITÀ A CAMME SOSPESA

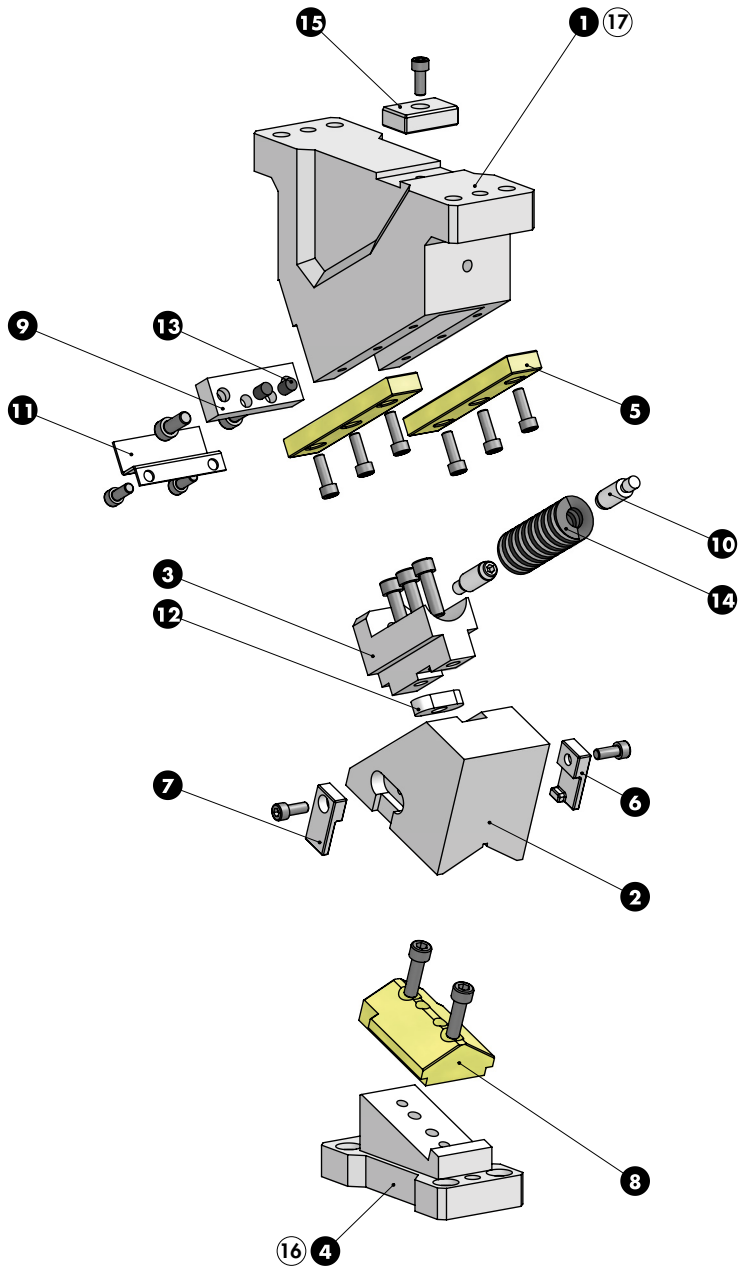

## AERIAL CAM UNIT - OBEN HÄNGENDER SCHIEBER - UNITÀ A CAMME SOSPESA

## SLIDER STRUCTURE, POSITIVE RETURN STRUCTURE AND CLEARANCES

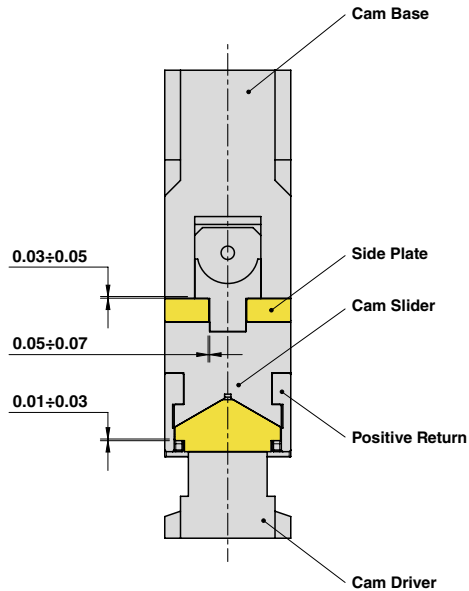

## PART LIST

Particular number	Description	Material	Quantity
1	Cam Base	GGG-45	1
2	Cam Slider	GG-25	1
3	Spring Guide Block	GGG-45 + Graphite	1
4	Cam Driver	GG-25	1
5	Side Plate	CuZn25Al5 + Graphite - HB > 190	2
6	Positive Return R	CK45	1
7	Positive Return L	CK45	1
8	Male "V" Driver	CuZn25Al5 + Graphite - HB > 190	1
9	Stopper Plate	St44	1
10	Spring Guide Pin	34CrMo4	2
11	Safety Plate	St44	1
12	Key	CK45	1
13	Elastomer Cap	Elastomer 92SH	2
14	Spring	-	1
15	Key	CK45	1
16	Cam Driver Fixing Screws M12x40 DIN 912	-	4
17	Cam Base Fixing Screws M12x45 DIN 912	-	4

## AERIAL CAM UNIT - OBEN HÄNGENDER SCHIEBER - UNITÀ A CAMME SOSPESA

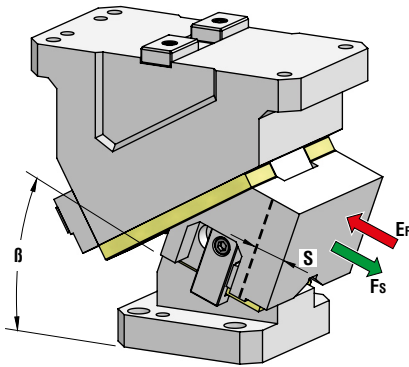

OMCR CODE	Work Angle	Max Stroke (mm)	Max Work Force with shoulder (kN)	Extraction Force (kN)
	$\beta$	S	F <sub>s</sub>	E <sub>f</sub> Spring
CLC150.00	0°	32,14	140	4,18
CLC150.05	5°	32,26	140	3,73
CLC150.10	10°	38,89	140	4,18
CLC150.15	15°	39,65	140	3,73
CLC150.20	20°	46,08	140	4,18
CLC150.25	25°	47,78	140	3,73
CLC150.30	30°	54,25	140	4,18
CLC150.35	35°	57,36	140	3,73
CLC150.40	40°	64,28	140	4,18
CLC150.45	45°	69,64	140	3,73
CLC150.50	50°	77,79	140	4,18
CLC150.55	55°	87,17	140	3,73
CLC150.60	60°	98,48	140	3,25
CLC150.65	65°	93,21	140	2,40
CLC150.70	70°	86,38	140	1,66

### OPTION CODE

N Ø16 H7

### OPTION CODE



Art.	Work Angle = 5°	N
CLC150	05	N16

OMCR CODE	Work Angle	Overall Dimensions (mm)				
	$\beta$	A	B	C	D	E
CLC150.00	0°	280	85	120	270	100
CLC150.05	5°	288,26	95,84	115	265	100
CLC150.10	10°	285,54	102,36	105	255	100
CLC150.15	15°	291,79	114,47	105	255	100
CLC150.20	20°	286,97	122,07	90	240	135
CLC150.25	25°	291,02	135,08	90	240	135
CLC150.30	30°	283,92	138,40	70	220	135
CLC150.35	35°	285,66	151,91	70	220	135
CLC150.40	40°	276,20	155,53	45	195	170
CLC150.45	45°	275,56	169,14	45	195	170
CLC150.50	50°	263,74	167,65	25	175	170
CLC150.55	55°	260,74	180,94	25	175	170
CLC150.60	60°	246,60	193,92	0	150	170
CLC150.65	65°	241,35	206,49	0	150	170
CLC150.70	70°	240,01	218,56	-5	145	170

## AERIAL CAM UNIT - OBEN HÄNGENDER SCHIEBER - UNITÀ A CAMME SOSPESA

### X VIEW

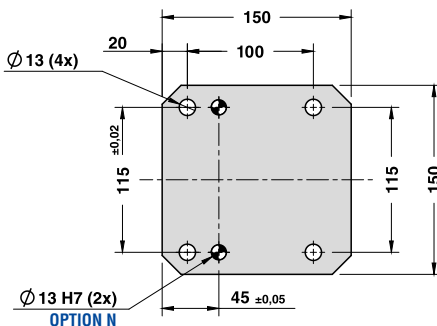
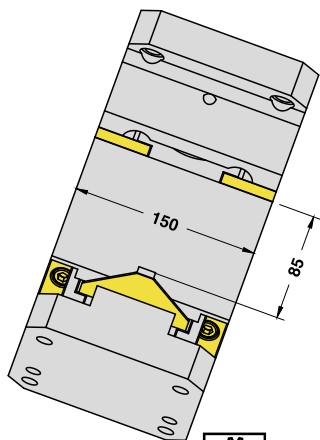

### CAM DIAGRAM

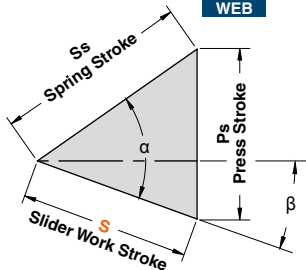

Work Angle	Inner Angle	Slider Work Stroke (mm)	Press Stroke (mm)	Spring Stroke (mm)
$\beta$	$\alpha$	S	Ps	Ss
0°	50°	32,14	38,30	50
5°	55°	32,26	41,11	50
10°	50°	38,89	38,89	50
15°	55°	39,65	42,40	50
20°	50°	46,08	40,76	50
25°	55°	47,78	45,19	50
30°	50°	54,25	44,23	50
35°	55°	57,36	50,00	50
40°	50°	64,28	50,00	50
45°	55°	69,64	57,92	50
50°	50°	77,79	59,59	50
55°	55°	87,17	71,41	50
60°	50°	98,48	76,60	50
65°	55°	93,21	77,53	40
70°	60°	86,38	75,96	30

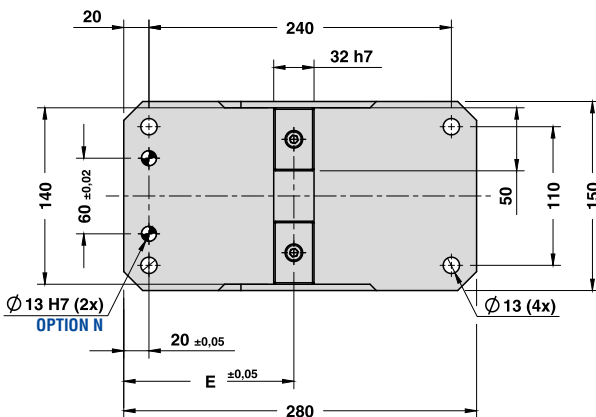
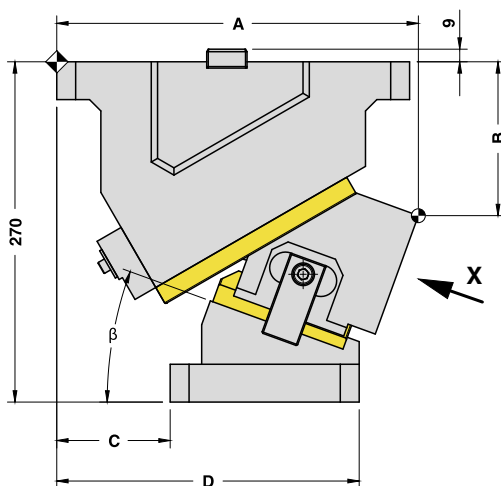

Cam Units CLC



**AERIAL CAM UNIT - OBEN HÄNGENDER SCHIEBER - UNITÀ A CAMME SOSPESA**

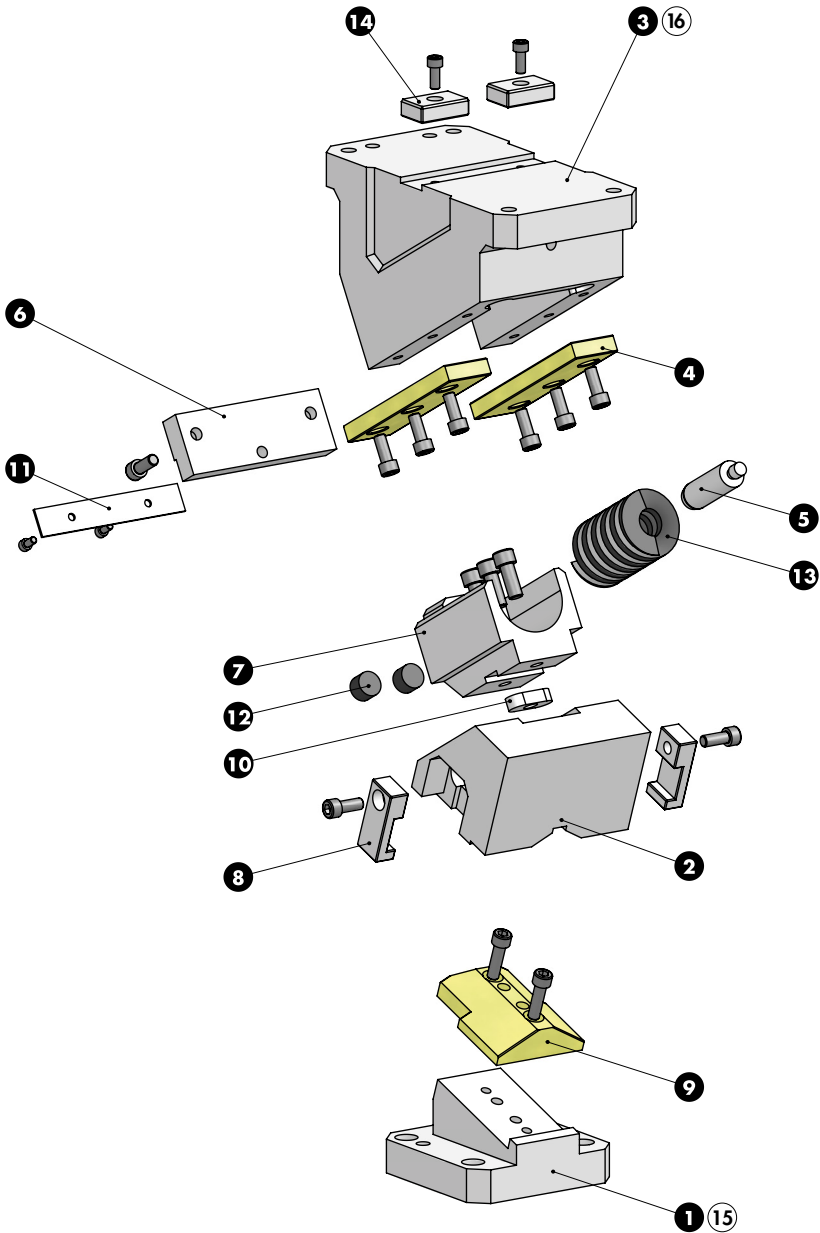

AERIAL CAM UNIT - OBEN HÄNGENDER SCHIEBER - UNITÀ A CAMME SOSPESA

SLIDER STRUCTURE, POSITIVE RETURN STRUCTURE AND CLEARANCES

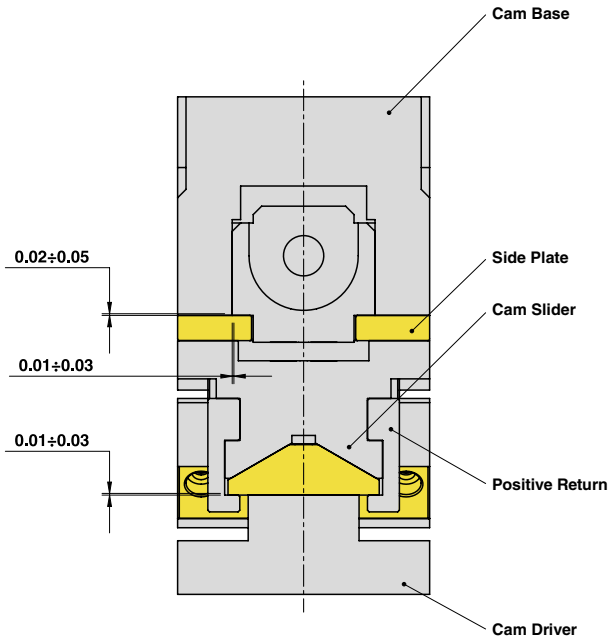

Cam Units CLC

PART LIST

Particular number	Description	Material	Quantity
1	Cam Driver	GG-25	1
2	Cam Slider	GG-25	1
3	Cam Base	GG-25	1
4	Side Plate	CuZn25Al5 + Graphite - HB > 190	2
5	Spring Guide Pin	34CrMo4	1
6	Stopper Plate	St44	1
7	Spring Guide Block	GGG-45 + Graphite	1
8	Positive Return	CK45	2
9	Male "V" Driver	CuZn25Al5 + Graphite - HB > 190	1
10	Key	CK45	1
11	Safety Plate	St44	1
12	Elastomer Cap	Elastomer 92SH	2
13	Spring	-	1
14	Key	CK45	2
15	Cam Driver Fixing Screws M12x45 DIN 912	-	4
16	Cam Base Fixing Screws M12x45 DIN 912	-	4